

DATA SHEET

5 FRAME PLUNGER PUMP

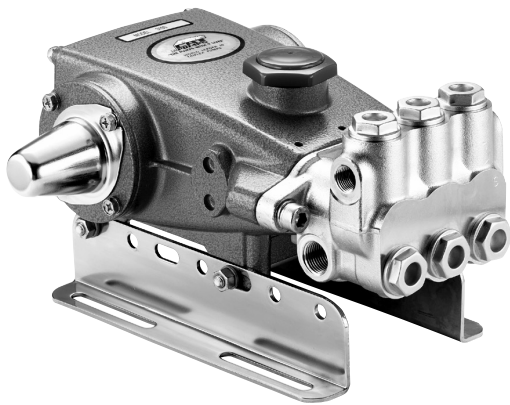

Standard Model: 300



Model 310 Shown
(Rails Sold Separately)

FEATURES

- Triplex design offers high efficiency and low pulsation.
- Durable high pressure seals are lubricated and cooled by pumped liquid.
- Pre-set Lo-Pressure Seals provide secondary protection against external leaks and require no packing adjustment.
- Alternate crankshaft strokes offers flexibility with belt, clutch or direct-drive installation.
- Standard NBR seals with alternative options for temperature and chemical compatibility
 - FPM – .0110
 - EPDM – .0220
 - High Temp, 190°F – .3000

SPECIFICATIONS	U.S. Measure	Metric Measure
Flow	2.6 gpm	10 lpm
Pressure Range	up to 2176 psi	up to 150 bar
Pump RPM	1420 rpm	1420 rpm
Inlet Pressure Range	up to 60 psi	up to 4 bar
Stroke	0.315"	8 mm
Bore	0.787"	20 mm
Standard Liquid Temperature	160°F	71°C
Above 130°F call Cat Pumps for inlet conditions and elastomer recommendations.		
Crankcase Capacity	18 oz.	0.55 l
Inlet Ports (2)	1/2" NPT(F)	1/2" NPT(F)
Discharge Ports (2)	3/8" NPT(F)	3/8" NPT(F)
Shaft Diameter	0.787"	20 mm
Weight	19.8 lbs.	9 kg
Dimensions	11.73 x 8.3 x 5.24"	298 x 210 x 133 mm

ELECTRIC HORSEPOWER REQUIREMENTS

FLOW		PRESSURE					RPM
		psi 1200	psi 1500	psi 1800	psi 2000	psi 2176	
U.S. gpm	lpm	bar 82	bar 103	bar 124	bar 138	bar 150	
2.6	10	2.1	2.7	3.2	3.6	3.9	1420

DETERMINING THE PUMP R.P.M.	$\frac{\text{Rated gpm}}{\text{Rated rpm}}$	=	$\frac{\text{"Desired" gpm}}{\text{"Desired" rpm}}$
DETERMINING THE REQUIRED H.P.	$\frac{\text{gpm} \times \text{psi}}{1460}$	=	$\frac{\text{Electric Brake H.P. Required}}{\text{H.P. Required}}$
DETERMINING MOTOR PULLEY SIZE	$\frac{\text{Motor Pulley O.D.}}{\text{Pump rpm}}$	=	$\frac{\text{Pump Pulley O.D.}}{\text{Motor rpm}}$

See complete Drive Packages [Incls: Pulleys, Belts, Hubs, Key] Tech Bulletin 003.
Refer to pump **Service Manual** for repair procedure and additional technical information.

PARTS LIST

ITEM	PART NUMBERS		DESCRIPTION	QTY
	300	MATL		
2	30057	STL	Key (M6x6x25)	1
5	125824	STCP R	Screw, HHC, Sems (M6x16)	8
8	43344	AL	Cover, Bearing	1
10	43343	NBR	O-Ring, Bearing Cover - 70D	2
11	43222	NBR	Seal, Oil, Crankshaft	1
15	14480	STL	Bearing, Ball	2
20	45883	HS	Rod, Connecting Assy [09/05]	3
25	44923	FCM	Crankshaft, Single End (300RS - Shaft end left side)	1
30	44949	AL	Cover, Blind Shaft	1
31	828710	—	Protector, Oil Cap w/Foam Gasket	1
32	43211	ABS	Cap, Oil Filler	1
33	14177	NBR	O-Ring, Filler Cap - 70D	1
37	92241	—	Gauge, Oil, Bubble w/Gasket	1
38	44428	NBR	Gasket, Flat, Oil Gauge - 80D	1
40	126541	STCP R	Screw, HHC, Sems (M6x20)	4
48	25625	STCP	Plug, Drain (1/4"x19 BSP)	1
49	23170	NBR	O-Ring, Drain Plug - 70D	1
50	48772	AL	Cover, Rear [10/01] (See Tech Bulletin 090)	1
51	48773	NBR	O-Ring, Rear Cover [10/01] (See Tech Bulletin 090)	1
53	48769	AL	Crankcase [05/02] (See Tech Bulletin 090)	1
56	43355	POP	Pan, Oil	1
64	43351	CM	Pin, Crosshead	3
65	43365	ZZCP	Rod, Plunger	3
70	43228	NBR	Seal, Oil, Crankcase	3
75	43328	S	Slinger, Barrier	3
88	45697	S	Washer, Keyhole (M18 x 10)	3
90	43367	CC	Plunger (M20x72)	3
96	43235	PTFE	Back-up-Ring, Plunger Retainer	3
97	17399	NBR	O-Ring, Plunger Retainer - 80D	3
	14160	FPM	O-Ring, Plunger Retainer - 80D	3
	◆ 46204	EPDM	O-Ring, Plunger Retainer - 70D	3
98	45891	CU	Gasket	3
99	104360	S	Retainer, Plunger w/Stud	3
100	45688	PVDF	Retainer, Seal, 2-Pc [04/06] (See Tech Bulletin 105)	3
101	43302	—	Wick, Long Tab	3
106	43305	NBR	Seal, LPS w/S-Spg	3
	45153	FPM	Seal, LPS w/SS-Spg	3
	◆ 48429	EPDM	Seal, LPS w/SS-Spg	3
	76305	ST2	Seal, LPS w/S-Spg	3
120	45679	BB	Case, Seal	3
121	14200	NBR	O-Ring, Seal Case - 70D	3
	11719	FPM	O-Ring, Seal Case	3
	◆ 48907	EPDM	O-Ring, Seal Case	3
125	43307	SNG	Seal, HPS w/S	3
	44936	FPM	Seal, HPS w/SS	3
	46667	HT	Seal, HPS "Hi-Temp", 2-Pc w/S-Support	3
139	22179	BBCP	Plug, Inlet [1/2" NPT(M)]	1
162	48361	D	Back-up-Ring, Seat	6
163	43358	NBR	O-Ring, Seat - 70D	6
	44938	FPM	O-Ring, Seat - 70D	6
	◆ 48908	EPDM	O-Ring, Seat	6
164	43725	S	Seat	6
166	43723	S	Valve	6
167	43750	S	Spring, Valve	6
168	44565	PVDF	Retainer, Valve Spring	6
172	17615	NBR	O-Ring, Valve Plug - 75D	6
	15855	FPM	O-Ring, Valve Plug - 70D	6
	◆ 48431	EPDM	O-Ring, Valve Plug - 75D	6
174	43849	BBCP	Plug, Valve	6
185	44837	BBCP	Head, Manifold	1
188	126520	STCP R	Screw, HSH, Sems (M10x35)	2
255	30243	STZP	Mount, Direct	1
260	126610	STZP	Mounting, Angle Rail	1
265	30659	—	Mount, Assy (Incls: 30611, 30633, 118672)	1

EXPLODED VIEW

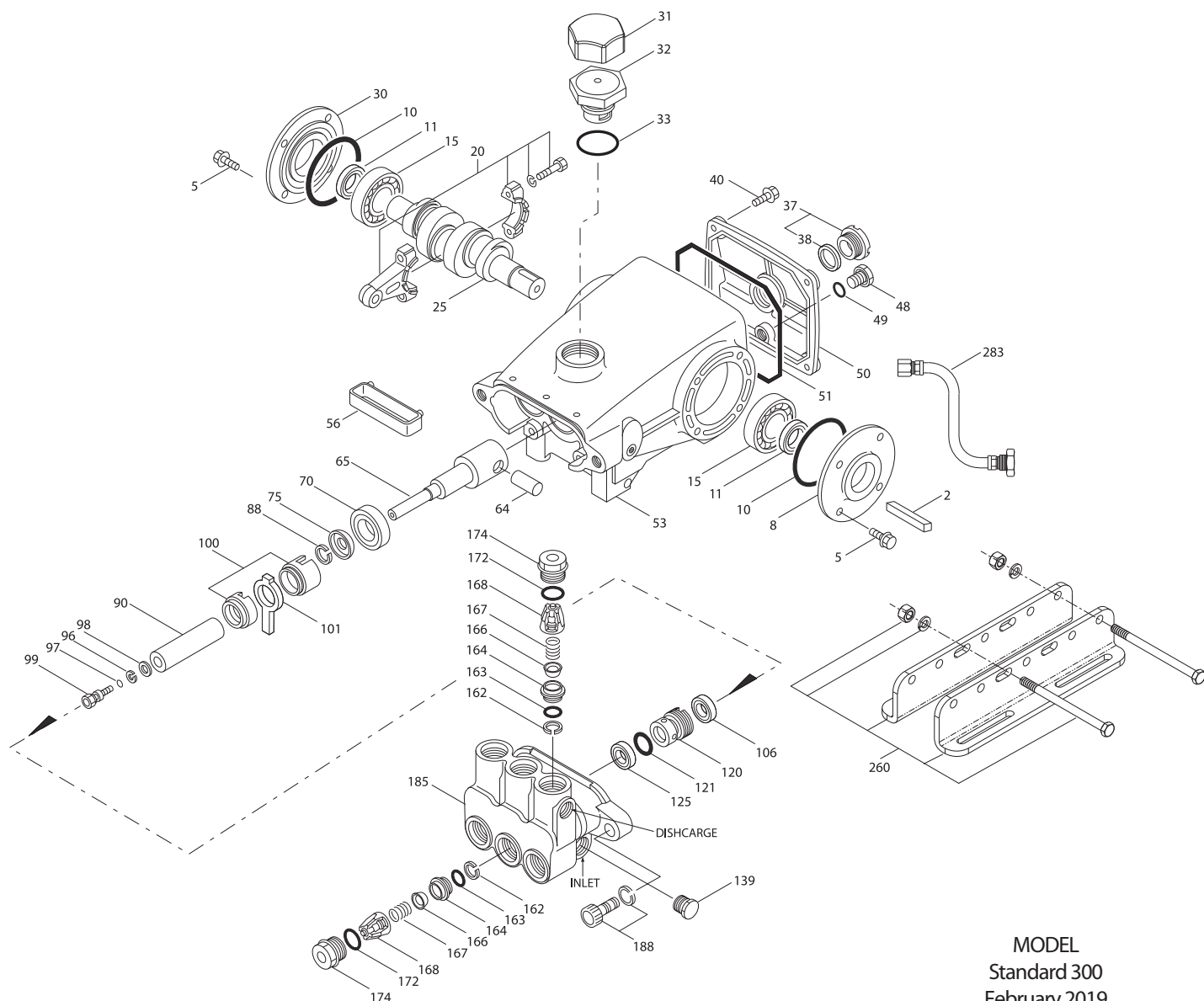

MODEL
Standard 300
February 2019

ITEM	PART NUMBERS	DESCRIPTION	QTY
	300	MATL	
283	34334	— Kit, Oil Drain (3/8" x 24") (See Individual Data Sheet)	1
	76334	— Kit, Oil Indicator, (3/8" x 24) (See Individual Data Sheet)	1
299	810027	BBCP Head, Complete Standard	1
300	30623	NBR Kit, Seal (Incls: 97, 101, 106, 121, 125) Standard	1
	34155	FPM Kit, Seal (Incls: 97, 101, 106, 121, 125) .0110	1
	33623	HT Kit, Seal, "Hi-Temp" (Incls: 97, 101, 106, 121, 125) .3000	1
	◆ 31163	EPDM* Kit, Seal (Incls: 97, 101, 106, 121, 125) .0220	1
310	30821	NBR Kit, Valve, Preassembled (Incls: 162-164, 166-168, 172) Standard, .3000	2
	31821	FPM Kit, Valve, Preassembled (Incls: 162-164, 166-168, 172) .0110	2
	◆ 31162	EPDM Kit, Valve, Preassembled (Incls: 162-164, 166-168, 172) .0220	2
350	30696	STZP Plier, Reverse	1
351	33004	STZP Socket, Seal Case	1
—	6107	— Oil, Bottle (21 oz.) ISO-68 Hydraulic (Fill to specified crankcase capacity prior to start-up)	1

Italics are optional items. ◆ Silicone oil/grease required.

R Components comply with RoHS Directive. [] Date of latest production change. *Review individual parts in each kit for material code identification.

View Tech Bulletins 002, 003, 008, 024, 027, 032, 035, 036, 043, 045, 046, 049, 052, 053, 054, 073, 074, 077, 079, 083, 090, 105 for additional information.

MATERIAL CODES (Not Part of Part Number): ABS=ABS Plastic AL=Aluminum BB=Brass BBCP=Brass/Chrome Plated CC=Ceramic CM=Chrome-moly CU=Copper D=Acetal EPDM=Ethylene Propylene Diene Monomer FCM=Forged Chrome-moly FPM=Fluorocarbon HS=High Strength HT=High Temp (EPDM Alternative) NBR=Medium Nitrile (Buna-N) POP=Polypropylene PTFE=Pure Polytetrafluoroethylene PVDF=Polyvinylidene Fluoride S=304SS SBCP=Special Brass/Chrome Plated SNG=Special Blend (Buna) ST2=Special PTFE 2 STL=Steel STCP=Steel/Chrome Plated STZP=Steel/Zinc Plated ZZCP=Chrome Plated/Steel - Zamak

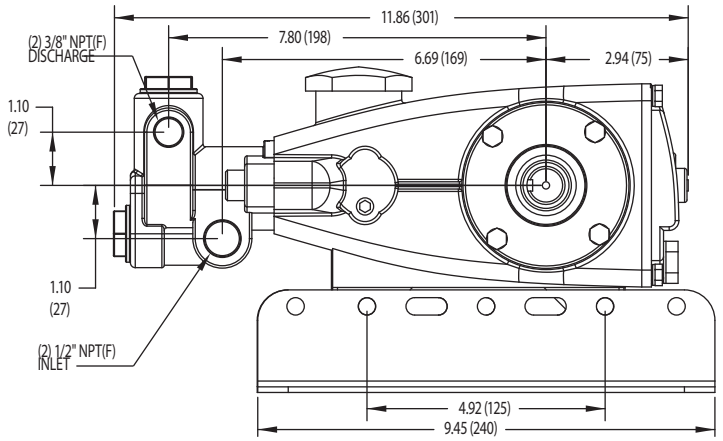
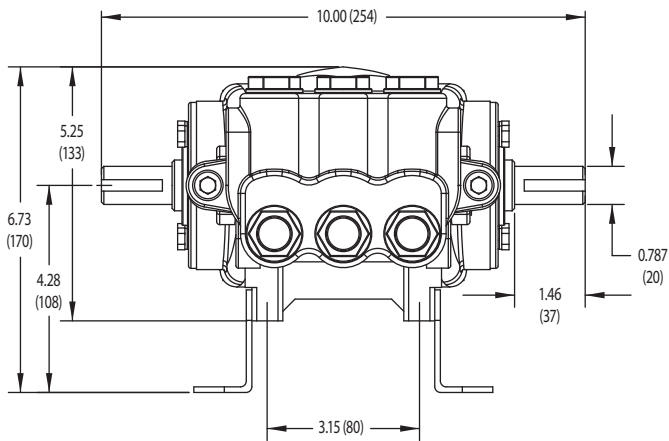

Model 310

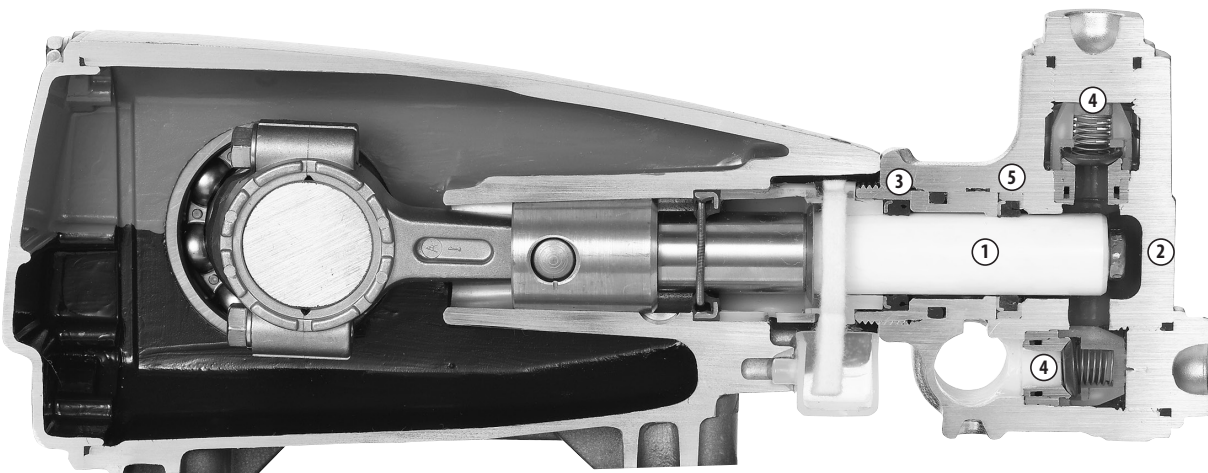

1. Special concentric, high-density, polished, solid ceramic **plungers** provide a true wear surface and extended seal life.
2. **Manifolds** are a high tensile strength forged brass or special brass for long life, continuous duty and compatibility.
3. 100% wet **seal** design adds to service life by allowing pumped liquids to cool and lubricate on both sides.
4. Stainless steel **valves, seats and springs** provide corrosion-resistance, ultimate seating and extended life.
5. Specially formulated, Cat Pumps exclusive, **Hi-Pressure Seals** offer unmatched performance and seal life.

⚠ CAUTIONS AND WARNINGS

All High Pressure Systems require a primary pressure regulating device (i.e. regulator, unloader) and a secondary pressure relief device (i.e. pop-off valve, relief valve). Failure to install such relief devices could result in personal injury or damage to pump or property. Cat Pumps does not assume any liability or responsibility for the operation of a customer's high pressure system.

Read all CAUTIONS and WARNINGS before commencing service or operation of any high pressure system. The CAUTIONS and WARNINGS are included in each service manual and with each Accessory Data sheet. CAUTIONS and WARNINGS can also be viewed online at www.catpumps.de or can be requested directly from CAT PUMPS.



CAT PUMPS DEUTSCHLAND GMBH
 BUCHWIESE 2-4, 65510 IDSTEIN - DEUTSCHLAND
 TEL. +49 (0)6126-9303-0 — FAX +49 (0)6126-9303-33
 E-Mail: info@catpumps.de
www.catpumps.de