

# DATA SHEET

## 3 FRAME PLUNGER PUMPS

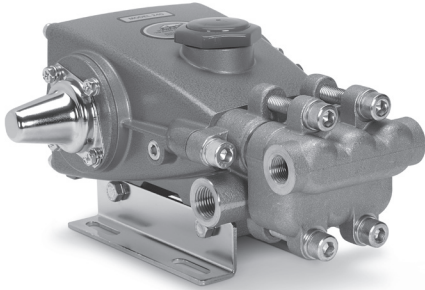

**Brass Models: 230, 240, 270**



Model 240 Shown  
(Shaft protector and mounting rails sold separately)

### FEATURES

- Triplex plunger design ensures high efficiency and low pulsation.
- Belt-driven option provides precision flow settings.
- Direct-drive option offers a compact footprint for electric motors with a NEMA or IEC frame, or SAE hydraulic motor with a bell housing/flexible coupler assembly.
- Pump comes standard with NBR seals. Alternative seal materials are available for higher temperature or chemical compatibility.

### COMMON SPECIFICATIONS

	U.S.	Metric
Bore	0.709"	18 mm
Inlet Pressure Range	Flooded to 60 psi	Flooded to 4.1 bar
Maximum Liquid Temperature	160° F	71° C
<b>Alternative seals available for higher temperature up to 200° F</b>		
Crankcase Capacity	15 oz	.45 l
Inlet Ports (2)	½" NPT(F)	½" NPT(F)
Discharge Ports (2)	¾" NPT(F)	¾" NPT(F)
Shaft Diameter	0.650"	16.5 mm
Pulley Mounting	Either Side	Either Side
Weight	13.9 lbs	6.3 kg
Dimensions	10.51 x 8.78 x 5.30"	267 x 223 x 134 mm

### SPECIFICATIONS

	U.S. Measure	Metric Measure
<b>230</b>		
Flow	2.3 gpm	8.7 lpm
Pressure Range	100–1500 psi	6.9–103 bar
Pump RPM*	1725 rpm	1725 rpm
Stroke	0.287"	7.3 mm
<b>240</b>		
Flow	3.6 gpm	13.6 lpm
Pressure Range	100–1200 psi	6.9–83 bar
Pump RPM*	1725 rpm	1725 rpm
Stroke	0.433"	11 mm
<b>270</b>		
Flow	3.5 gpm	13.2 lpm
Pressure Range	100–1500 psi	6.9–103 bar
Pump RPM*	1420 rpm	1420 rpm
Stroke	0.500"	12.7 mm

### ALTERNATE SPECIFICATIONS

<b>270</b>		
Flow	4.2 gpm	15.9 lpm
Pressure Range	100–1000 psi	6.9–69 bar
Pump RPM*	1725 rpm	1725 rpm
Stroke	0.500"	12.7 mm

\*Pump minimum is 100 RPM.

### ALTERNATIVE SEAL CONFIGURATION

MATERIAL	SUFFIX CODE	MAXIMUM TEMPERATURE	
NBR	—	160° F	(71° C)
FPM	.0110	180° F	(82° C)
EPDM	.0220	160° F	(71° C)
IPFE	.0770	200° F	(93° C)
HT	.3000	180° F	(82° C)
STHT	.3400	190° F	(88° C)

See **Tech Bulletin 002** for inlet conditions and RPM at higher temperatures.

<b>DETERMINING THE PUMP RPM</b>	Rated gpm	=	Desired gpm
	Rated rpm	=	Desired rpm
<b>DETERMINING THE REQUIRED HP</b>	hp	=	gpm x psi
	(Electric Brake)	=	1460
<b>DETERMINING MOTOR PULLEY SIZE</b>	Motor Pulley OD	=	Pump Pulley OD
	Pump rpm	=	Motor rpm

Refer to pump **Service Manual** for repair procedure and additional technical information.

# PARTS LIST

ITEM	PART		PART		PART		DESCRIPTION	QTY
	NUMBER	MATL	NUMBER	MATL	NUMBER	MATL		
	<b>230</b>		<b>240</b>		<b>270</b>			
5	125824	STCP R	125824	STCP R	125824	STCP R	Screw, HHC Sems (M6 x 16) (See Tech Bulletin 074)	8
8	27950	AL	27950	AL	27950	AL	Cover, Bearing	2
10	26536	NBR	26536	NBR	26536	NBR	O-Ring, Oil Seal Case-70D	2
11	24159	NBR	24159	NBR	24159	NBR	Seal, Oil	2
15	14487	STL R	14487	STL R	14487	STL R	Bearing, Ball	2
20	48867	TNM	48867	TNM	48867	TNM	Rod, Connecting Assembly (See Tech Bulletin 074)	3
25	<b>46946</b>	FCM	<b>46951</b>	FCM	<b>108062</b>	FCM	Crankshaft, Dual End	1
32	43211	ABS	43211	ABS	43211	ABS	Cap, Oil Filler	1
33	14177	NBR	14177	NBR	14177	NBR	O-Ring, Oil Filler Cap-70D	1
37	92241	—	92241	—	92241	—	Gauge, Oil, Bubble with Gasket-80D	1
38	44428	NBR	44428	NBR	44428	NBR	Gasket, Flat, Oil Gauge-80D	1
40	126541	STCP R	126541	STCP R	126541	STCP R	Screw, HHC Sems (M6 x 20) (See Tech Bulletin 074)	6
48	25625	STCP	25625	STCP	25625	STCP	Plug, Drain (1/4" x 19 BSP)	1
49	23170	NBR	23170	NBR	23170	NBR	O-Ring, Drain Plug-70D	1
50	48772	AL	48772	AL	48772	AL	Cover, Rear (See Tech Bulletin 104)	1
51	48773	NBR	48773	NBR	48773	NBR	O-Ring, Rear Cover (See Tech Bulletin 104)	1
53	128354	AL	128354	AL	128354	AL	Crankcase (See Tech Bulletin 104)	1
64	16948	CM	16948	CM	16948	CM	Pin, Crosshead	3
65	45114	SSZZ	45114	SSZZ	45114	SSZZ	Rod, Plunger	3
69	126259	STCP R	126259	STCP R	126259	STCP R	Washer, Oil (M24)	3
70	25301	NBR	25301	NBR	25301	NBR	Seal, Oil-80D	3
71	126189	STCP R	126189	STCP R	126189	STCP R	Washer, Oil Seal	3
75	43900	S	43900	S	43900	S	Slinger, Barrier	3
88	45697	S	45697	S	45697	S	Washer, Keyhole (M18 x 10)	3
90	43901	CC	43901	CC	43901	CC	Plunger (M18 x 43)	3
95	126550	STCP R	126550	STCP R	126550	STCP R	Stud, Plunger Retainer (M6 x 43)	3
96	43235	PTFE	43235	PTFE	43235	PTFE	Backup Ring, Plunger Retainer	3
97	17399	NBR	17399	NBR	17399	NBR	O-Ring, Plunger Retainer-80D	3
98	45891	CU	45891	CU	45891	CU	Gasket, Plunger Retainer (M12.5)	3
99	46504	S	46504	S	46504	S	Retainer, Plunger (M6) (See Tech Bulletin 074)	3
100	28597	PVDF	28597	PVDF	28597	PVDF	Retainer, Seal	3
106	43243	NBR	43243	NBR	43243	NBR	Seal, LPS with S-Spring	3
110	43902	BB	43902	BB	43902	BB	Manifold, Inlet	1
117	126520	STCP R	126520	STCP R	126520	STCP R	Screw, HSH Sems (M10 x 35) (See Tech Bulletin 074)	2
125	43245	SNG	43245	SNG	43245	SNG	Seal, HPS	3
139	22179	BBCP	22179	BBCP	22179	BBCP	Plug, Inlet [1/2" NPT(M)]	1
143	17547	NBR	17547	NBR	17547	NBR	O-Ring, Inlet Valve Adapter, Rear-85D	3
150	43904	BB	43904	BB	43904	BB	Adapter, Inlet Valve	3
154	43893	NBR	43893	NBR	43893	NBR	O-Ring, Inlet Valve Adapter, Front-80D	3
155	26089	NBR	26089	NBR	26089	NBR	O-Ring, Discharge Valve Adapter, Rear-80D	3
157	43905	BB	43905	BB	43905	BB	Adapter, Discharge Valve	3
159	26089	NBR	26089	NBR	26089	NBR	O-Ring, Discharge Valve Adapter, Front-80D	3
164	44002	S	44002	S	44002	S	Seat	6
165	44001	NBR	44001	NBR	44001	NBR	O-Ring, Seat-80D	6
166	43723	S	43723	S	43723	S	Valve	6
167	43750	S	43750	S	43750	S	Spring	6
168	43907	S	43907	S	43907	S	Retainer, Spring	6
185	43903	BB	43903	BB	43903	BB	Manifold, Discharge	1
186	126231	STCP R	126231	STCP R	126231	STCP R	Lockwasher (M10)	4
188	126515	STCP R	126515	STCP R	126515	STCP R	Screw, HSH (M10 x 55) (See Tech Bulletin 074)	4

**Bold print part numbers are unique to a particular pump model. Italics are optional items.**

R Components comply with RoHS Directive. For additional technical information see [www.catpumps.com/literature/tech-bulletins](http://www.catpumps.com/literature/tech-bulletins).

MATERIAL CODES (Not Part of Part Number): AL=Aluminum ABS=ABS Plastic BB=Brass BBCP=Brass/Chrome Plated CC=Ceramic CM=Chrome-Moly CU=Copper  
 EPDM=Ethylene Propylene Diene Monomer FCM=Forged Chrome-moly FPM=Fluorocarbon HT=Hi-Temp (EPDM Alternative) IPFE=I-Perfluoroelastomer NBR=Medium Nitrile (Buna-N)  
 PC=Poly Carbonate PE=Polyethylene PTFE=Pure Polytetrafluoroethylene PVDF=Polyvinylidene Fluoride S=304SS SSZZ=316SS/Zamak SFTA=Special Blend PTFE  
 SNG=Special Blend (Buna) ST4=Special PTFE 4 STCP=Steel/Chrome Plated SHT=Special PTFE High Temp STL=Steel STZ=Special PTFE 2  
 STZP=Steel/Zinc Plated TNM=Special High Strength

# EXPLODED VIEW

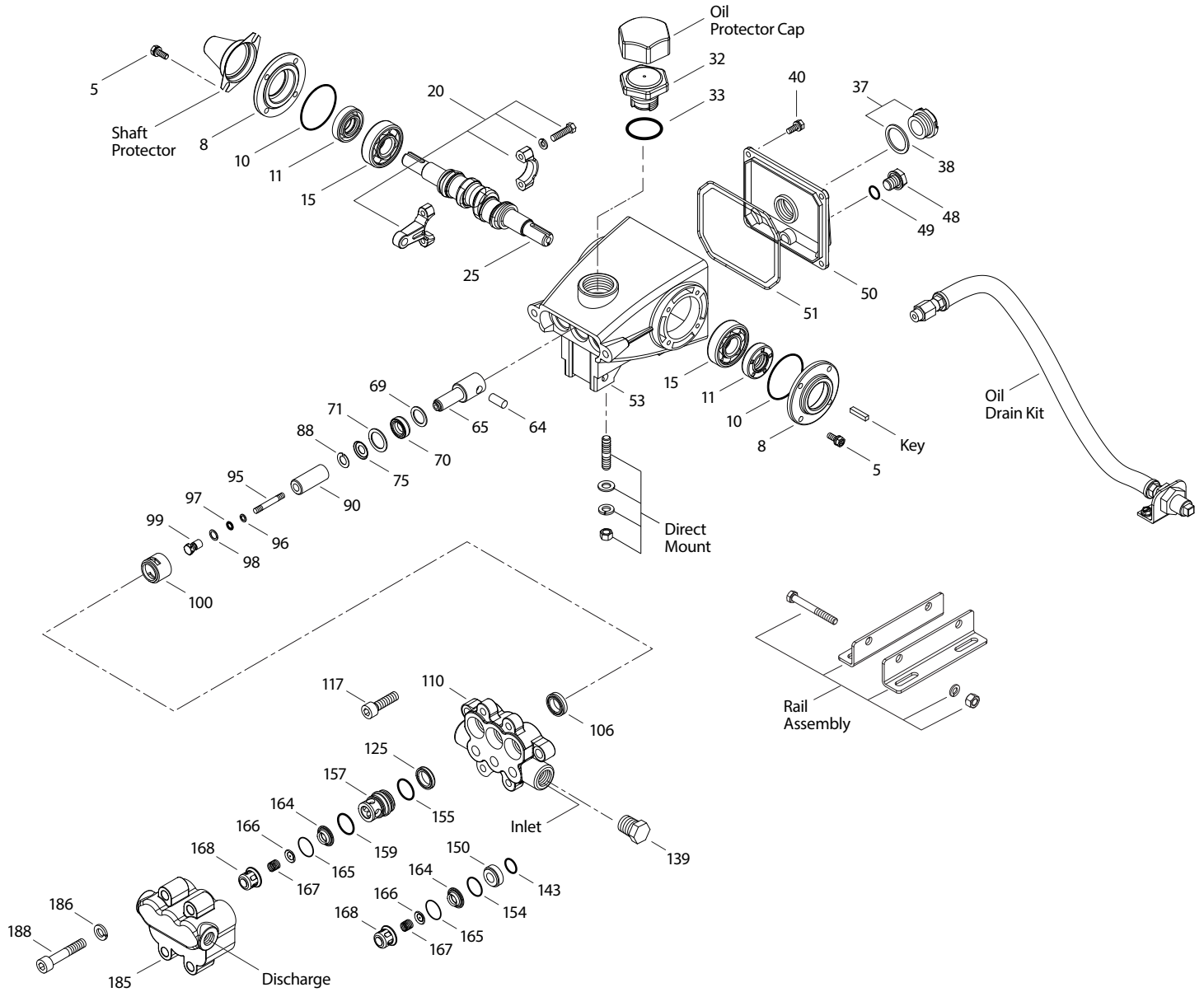

Models  
Brass 230, 240, 270  
August 2021

## OPTIONAL PARTS AND ACCESSORIES

PART	DESCRIPTION	QTY
30047	Key (M5 x 5 x 24)	1
30612	Assembly, Rail	1
30651	Assembly, Mount, Rail	1
30243	Mount, Direct	1
828710	Protector, Oil Cap	1
25130	Protector, Shaft	1
34334	Kit, Oil Drain (3/8" x 24")	1
30246	5" Pulley with Key	1

## SERVICE PARTS

PART	DESCRIPTION	QTY
30914	Kit, Seal-Standard NBR	1
30915	Kit, Valve-Standard NBR	1
6107	Oil, Bottle (21 oz) ISO 68 Hydraulic (Fill to Specified Crankcase Capacity Prior to Start-up)	1
6124	Gasket, Liquid (3 oz)	1
6139	Lubricant, Anti-Seize (8 oz)	1

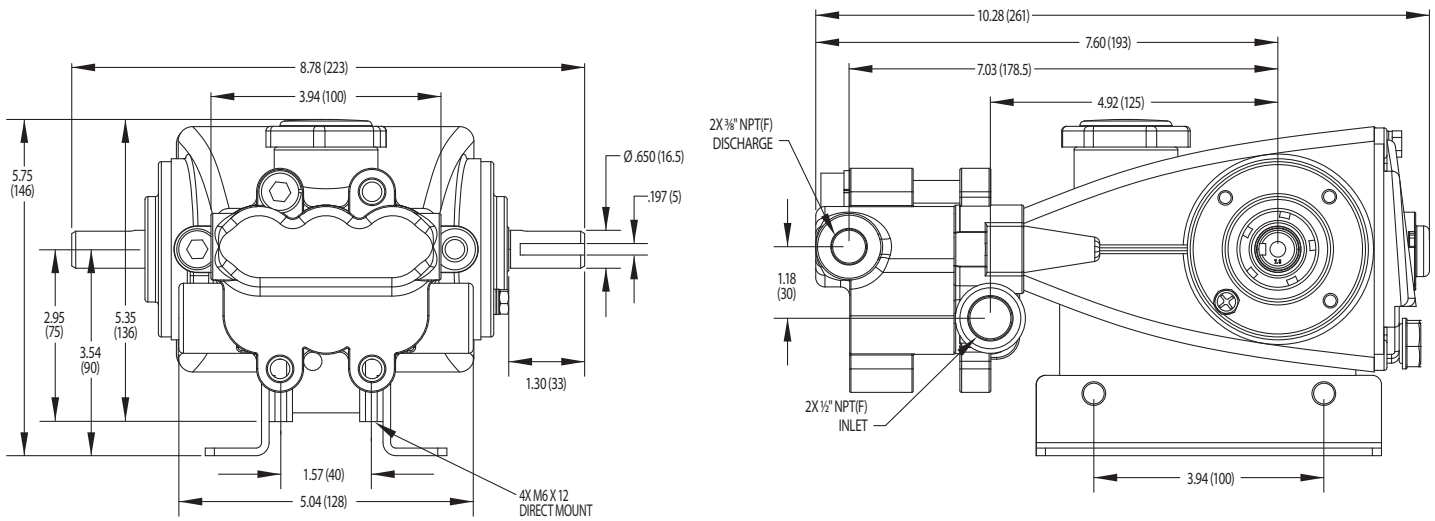

Models 230, 240, 270

### SEAL KITS One (1) seal kit required per pump

PUMP MODELS	NBR (STD)	FPM (.0110)	EPDM (.0220)◆	IPFE (.0770)	HT (.3000)	STHT (.3400)
230, 240, 270	<b>30914</b>	<b>33609</b>	<b>33914*</b>	<b>76660</b>	<b>33915</b>	<b>30735</b>

ITEM (Included in Seal Kits)							DESCRIPTION	QTY
97	17399	14160	46204	701715	17399	17399	O-Ring, Plunger Retainer	3
106	43243	44926	46651	702390	44053	76243	Seal, LPS with SS-Spring	3
125	43245	44925	46652	701382	46652	46652	Seal, High-Pressure	3
143	17547	11685	46648	703308	17547	17547	O-Ring, Inlet Valve Adapter, Rear	3
154	43893	44927	46649	703307	43893	43893	O-Ring, Inlet Valve Adapter, Front	3
155	26089	11377	46647	703244	26089	26089	O-Ring, Discharge Valve Adapter, Rear	3
159	26089	11377	46647	703244	26089	26089	O-Ring, Discharge Valve Adapter, Front	3
165	44001	44928	46650	703309	44001	44001	O-Ring, Seat	6

◆ Silicone oil/grease required \*Review material codes for individual items (HT generally may be used as alternative)

### VALVE KITS One (1) valve kit required per pump

PUMP MODELS	NBR (STD)	FPM (.0110)	EPDM (.0220)◆	IPFE (.0770)	HT (.3000)	STHT (.3400)
230, 240, 270	<b>30915</b>	<b>31214</b>	<b>31215</b>	<b>76690</b>	<b>30915</b>	<b>30915</b>

ITEM (Included in Valve Kits)							DESCRIPTION	QTY
143	17547	11685	46648	703308	17547	17547	O-Ring, Inlet Valve Adapter, Rear	3
154	43893	44927	46649	703307	43893	43893	O-Ring, Inlet Valve Adapter, Front	3
159	26089	11377	46647	703244	26089	26089	O-Ring, Discharge Valve Adapter, Rear	3
164	44002	44002	44002	44058	44002	44002	Seat	6
165	44001	44928	46650	703309	44001	44001	O-Ring, Seat	6
166	43723	43723	43723	44057	43723	43723	Valve	6
167	43750	43750	43750	44056	43750	43750	Spring	6
168	43907	43907	43907	44055	43907	43907	Retainer, Spring	6

◆ Silicone oil/grease required

#### ⚠ CAUTIONS AND WARNINGS

All high-pressure systems require a primary pressure regulating device (i.e. regulator, unloader) and a secondary pressure relief device (i.e. pop-off valve, relief valve). Failure to install such relief devices could result in personal injury or damage to pump or property. Cat Pumps does not assume any liability or responsibility for the operation of a customer's high-pressure system. Read all CAUTIONS and WARNINGS before commencing service or operation of any high-pressure system. The CAUTIONS and WARNINGS are included in each Service Manual and with each Accessory Data sheet. CAUTIONS and WARNINGS can also be viewed online at [www.catpumps.com/dynamic-literature/cautions-and-warnings](http://www.catpumps.com/dynamic-literature/cautions-and-warnings) or can be requested directly from Cat Pumps.

#### WARRANTY

View the Limited Warranty online at [www.catpumps.com/literature/cat-pumps-limited-warranty](http://www.catpumps.com/literature/cat-pumps-limited-warranty)