

DATA SHEET

15 FRAME PLUNGER PUMPS



**Brass
Model**
1530

**Brass Flushed
Model**
1530C

**Stainless Steel
Model**
1531

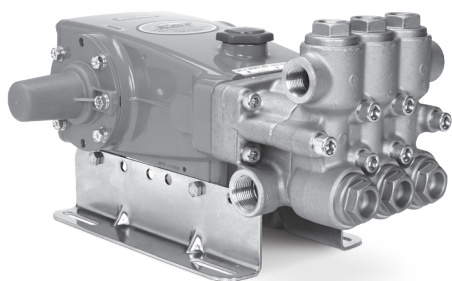

Model 1530 Shown
(Shaft protector included mounting rails sold separately)

FEATURES

- Triplex plunger design ensures high efficiency and low pulsation.
- V-packings and low-pressure seals are completely lubricated and cooled by pumped liquid, greatly increasing service life.
- Belt-driven option provides precision flow setting.
- Direct-drive option offers a compact footprint for electric motors with a NEMA or IEC frame, or SAE hydraulic motors with a bell housing/flexible coupler assembly.
- Model 1530C offers an external flush for high-temperature or low-lubricity liquids.
- Pump comes standard with NBR seals. Alternative seal materials are available for higher temperature or chemical compatibility.

SPECIFICATIONS

	U.S. Measure	Metric Measure
Flow	15.6 gpm	59 lpm
Pressure Range	100–1500 psi	6.9–103 bar
Pump RPM*	1450 rpm	1450 rpm
Inlet Pressure Range	Flooded to 70 psi	Flooded to 4.8 bar
Max. Liquid Temperature. (NBR)	140° F	60° C
Alternate seals available for higher temperatures up to 200° F		
Bore	0.984"	25 mm
Stroke	1.181"	30 mm
Crankcase Capacity	42 oz	1.26 l
Inlet Ports (2)	1" NPT(F)	1" NPT(F)
Flush Ports (2) 1530C	¼" NPT(F)	¼" NPT(F)
Discharge Ports (2)	¾" NPT(F)	¾" NPT(F)
Pulley Mounting	Either Side	Either Side
Shaft Diameter	1.181"	30 mm
Weight	1530, 1530C 1531	55 lbs 25 kg 53 lbs 24 kg
Dimensions	17.24 x 12.99 x 7.40"	438 x 330 x 188 mm

*Pump minimum is 100 RPM.

ALTERNATIVE SEAL CONFIGURATION

MATERIAL	SUFFIX CODE	MAXIMUM TEMPERATURE
NBR	—	140° F (60° C)
FPM	.0110	180° F (82° C)
EPDM	.0220	160° F (71° C)
FFKM	.0770	200° F (93° C)

See **Tech Bulletin 002** for inlet conditions and RPM at high-temperature.

$$\frac{\text{DETERMINING THE PUMP RPM}}{\text{Rated gpm}} = \frac{\text{Desired gpm}}{\text{Rated rpm}}$$

$$\frac{\text{DETERMINING THE REQUIRED HP}}{\text{hp (Electric Brake)}} = \frac{\text{gpm x psi}}{1460}$$

$$\frac{\text{DETERMINING MOTOR PULLEY SIZE}}{\text{Motor Pulley OD}} = \frac{\text{Pump Pulley OD}}{\text{Pump rpm}}$$

Refer to pump **Service Manual** for repair procedure and additional technical information.

PARTS LIST

ITEM	PART NUMBER	MATL	PART NUMBER	MATL	DESCRIPTION	QTY
	1530/1530C		1531			
5	126540	STCP R	49651	S	Screw, Sems HHC (M8 x 20) (See Tech Bulletins 074, 128)	8
8	134805	ALE	134805	ALE	Cover, Bearing (See Tech Bulletins 118, 128)	2
9	855043	FBR	855043	FBR	Shim, Split 2-Piece, Bearing Cover (See Tech Bulletin 128)	0-2
10	11340	NBR	11340	NBR	O-Ring, Bearing Cover-70D	2
11	43495	NBR	43495	NBR	Seal, Oil, Crankshaft	2
12	855044	SS	855044	SS	Shim, Split 2-Piece, Bearing Cover (See Tech Bulletin 128)	0-2
15	39060	STL	39060	STL	Bearing, Roller	2
20	48600	TNM	48600	TNM	Rod, Connecting Assembly (See Tech Bulletin 074)	3
25	43494	FCM	43494	FCM	Crankshaft, Dual-End (M30)	1
32	43211	ABS	43211	ABS	Cap, Oil Filler	1
33	14177	NBR	14177	NBR	O-Ring, Filler Cap-70D	1
37	92241	PC	92241	PC	Gauge, Oil, Bubble with Gasket-80D (See Tech Bulletin 074)	1
38	44428	NBR	44428	NBR	Gasket, Flat, Oil Gauge-80D	1
40	126541	STCP R	92542	S	Screw, Sems HHC (M6 x 20) (See Tech Bulletin 074)	4
48	25625	STCP	25625	STCP	Plug, Drain (1/4" x 19 BSP)	1
49	23170	NBR	23170	NBR	O-Ring, Drain Plug-70D	1
50	133576	ALE	133576	ALE	Cover, Rear (See Tech Bulletin 118)	1
51	44834	NBR	44834	NBR	O-Ring, Rear Cover-70D	1
53	134889	ALE	134889	ALE	Crankcase (Includes Guide Pins) (See Tech Bulletins 118, 128)	1
54	27488	S	27488	S	Pin, Guide	2
56	44664	POP	44664	POP	Pan, Oil	1
64	43507	CM	43507	CM	Pin, Crosshead	3
65	48228	SHS	—	—	Rod, Plunger, Long	3
	—	—	48360	SSHS	Rod, Plunger, Short	3
69	126592	STCP R	126592	STCP R	Washer, Oil Seal	3
70	43500	NBR	43500	NBR	Seal, Oil Crankcase	3
75	43506	S	43506	S	Slinger, Barrier	3
90	48606	CC	48606	CC	Plunger, Ceramic (M25 x 92)	3
95	—	—	89651	SS	Stud, Plunger Retainer (M6 x 70)	3
96	43235	PTFE	43235	PTFE	Backup Ring, Plunger Retainer	3
97	17399	NBR	17399	NBR	O-Ring, Plunger Retainer-80D	3
98	45891	CU	44041	SS	Gasket, Plunger Retainer	3
99	104360	S	44031	SS	Retainer, Plunger (See Tech Bulletin 074)	3
100	899509	POP	899509	POP	Retainer, Seal 2-Piece	3
101	48716	—	48716	—	Wick, Long Tab	3
106	44086	NBR	44086	NBR	Seal, Low-Pressure with SS-Spring	3
110	48608	FBB	48683	SS	Manifold, Inlet	1
	48608C	FBB	—	—	Manifold, Inlet Flushed (1/4" NPT[F] Port)	1
112	14200	NBR	14200	NBR	O-Ring, Inlet Manifold-70D	3
117	126515	STCP R	87952	S	Screw, HSH (M10 x 55) (See Tech Bulletin 074)	4
126	48538	BB	48669	D	Adapter, Female	3
	—	—	76667	SS	Adapter, Female	3
127	44610	STG	44610	STG	V-Packing	6
128	48539	BB	113025	SS	Adapter, Male	3
141	48672	SS	48672	SS	Spring, Coil	18
142	48550	BB	48670	SS	Spacer with Coil Springs	3
155	17629	NBR	17629	NBR	O-Ring, Spacer-80D	6
156	28243	PTFE	28243	PTFE	Backup Ring, Spacer	6
162	48363	D	48363	D	Backup Ring, Seat	6
163	26142	NBR	26142	NBR	O-Ring, Seat-80D	6
164	48596	S	48688	SS	Seat	6
166	670108	SS	670108	SS	Valve	6
167	48687	SS	48687	SS	Spring, Valve	6
168	44735	PVDF	44735	PVDF	Retainer, Spring	6
170	44794	SS	44794	SS	Washer, Spring Retainer	6
171	48689	SS	48689	SS	Spring, Coil	6
172	17629	NBR	17629	NBR	O-Ring, Valve Plug-80D	6
174	48597	FBB	49294	SSZZ	Plug, Valve (See Tech Bulletin 074)	6
185	48610	FBB	48685	SS	Manifold, Discharge	1
188	126519	STCP R	89981	SS	Screw, HSH (M12 x 70) (See Tech Bulletin 074)	6
250	855046	NY	855047	NY	Protector, Shaft with 2 Screws (See Tech Bulletin 128)	1

Bold print part numbers are unique to a particular pump model. Italics are optional items.

[] Date of latest production change. ♦ Silicone oil/grease required. R Components comply with RoHS Directive.

* Review material codes for individual items (STG generally may be used as alternate). For additional technical information see www.catpumps.com/literature/tech-bulletins.

MATERIAL CODES (Not Part of Part Number): ABS=ABS Plastic ALE=Aluminum Epoxy BB=Brass CC=Ceramic CM=Chrome-moly CU=Copper D=Acetal

EPDM=Ethylene Propylene Diene Monomer F=Cast Iron FBB=Forged Brass FBR=Fiber FCM=Forged Chrome-moly FFKM=Perfluoroelastomer

FPM=Fluorocarbon NBR=Medium Nitrile (Buna-N) NY=Nylon PC=Poly Carbonate PE=Polyethylene POP=Polypropylene

PTFE=Pure Polytetrafluoroethylene PVDF=Polyvinylidene Fluoride S=304SS SFTA=Special Blend PTFE Tan

SFTB=Special Blend PTFE Black SHS=304SS/High Strength SS=316SS SSSHS=316SS/High Strength

SSZZ=316SS/Zamak STCP=Steel/Chrome Plated STG=Special Blend PTFE White STL=Steel

STZP=Steel/Zinc Plated TNM=Special High Strength

EXPLODED VIEW

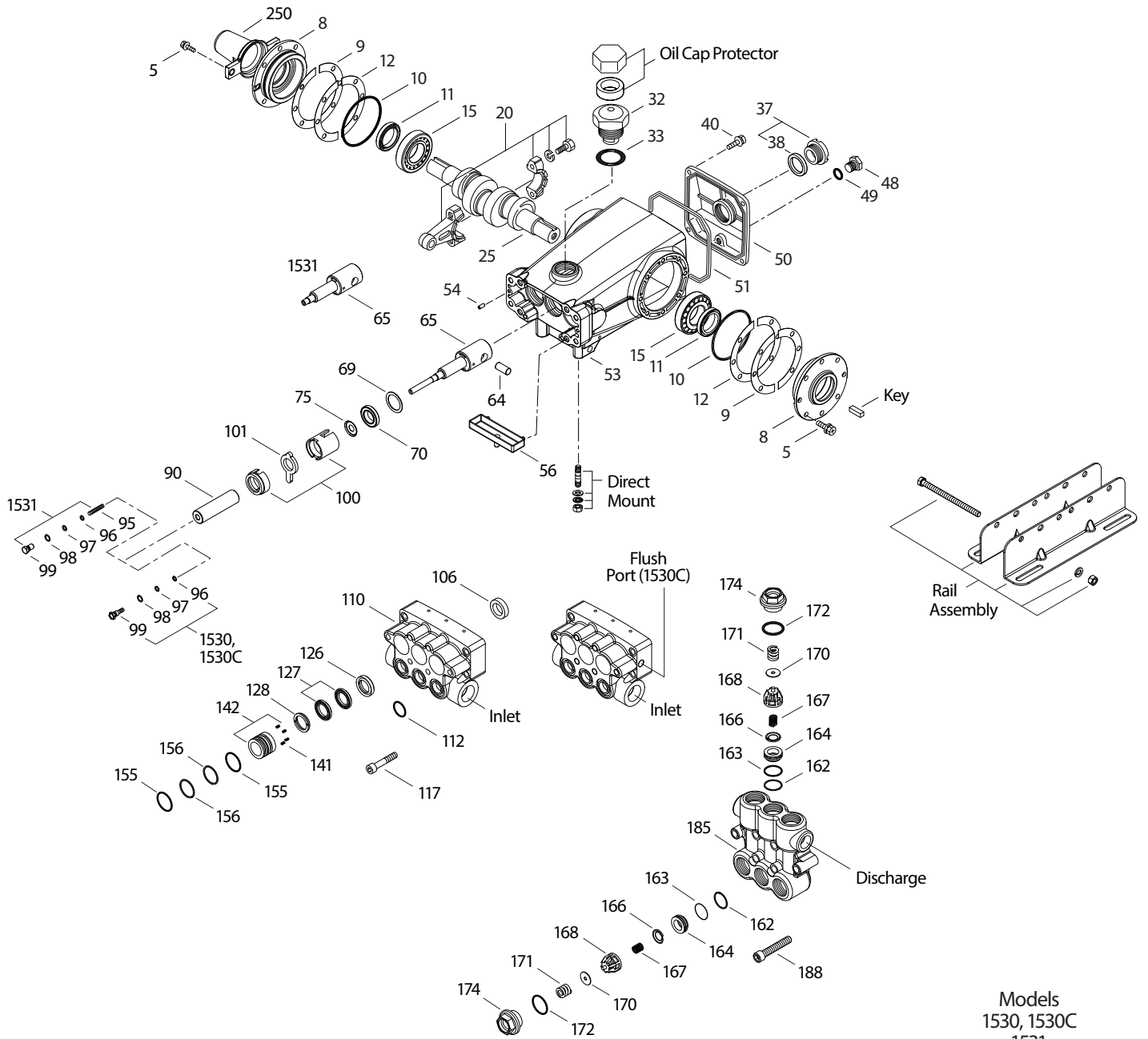

Models
1530, 1530C
1531
June 2023

OPTIONAL PARTS AND ACCESSORIES

PART	DESCRIPTION	QTY
30067	Key, (M8 x 7.5 x 25)	1
990036	Key, (M8 x 7 x 40)	1
30613	Assembly, Rail (5.72" See Dimensional Drawing)	1
76513	Assembly, Rail (6.22" See Dimensional Drawing)	1
990550	Assembly, Rail, Diesel (5.72" See Dimensional Drawing)	1
30264	Mount, Direct	1
828710	Protector, Oil Cap	1
34334	Kit, Oil Drain (Not Shown)	1
30206	Pulley, 10", 2-Groove H (Not Shown)	1
30059	Hub, H, 30mm (Not Shown)	1
990012	Hub, B, 30mm (Not Shown)	1

SERVICE PARTS

PART	DESCRIPTION	QTY
31355	Kit, Seal – Standard NBR	1
31360	Kit, Valve Standard NBR (Models 1530, 1530C)	2
31271	Kit, Valve – Standard NBR (Model 1531)	2
6107	Oil, Bottle (21 oz) (Fill to Specified Crankcase Capacity Prior to Start-up)	2
6124	Gasket, Liquid (3 oz)	1
6139	Lubricant, Anti-Seize (3 oz) (Model 1531)	1
816762	Head, Complete with NBR Seals and O-Rings (Model 1530)	1
816783	Head, Complete with NBR Seals and O-Rings (Model 1531)	1

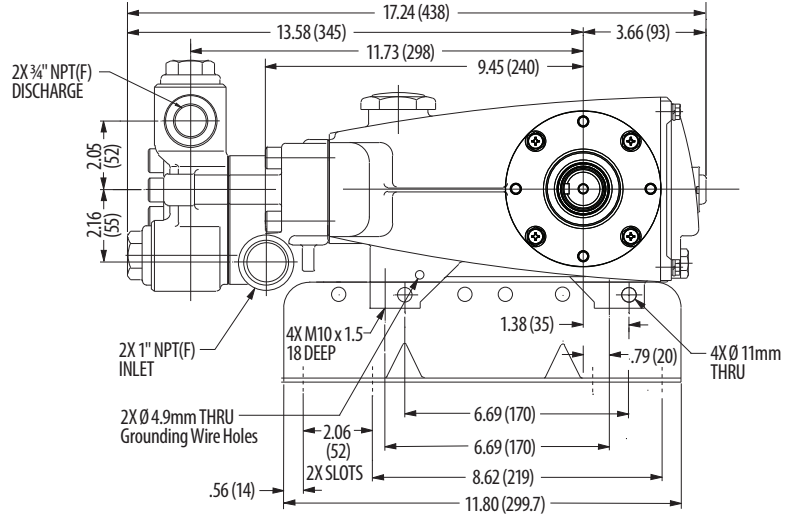
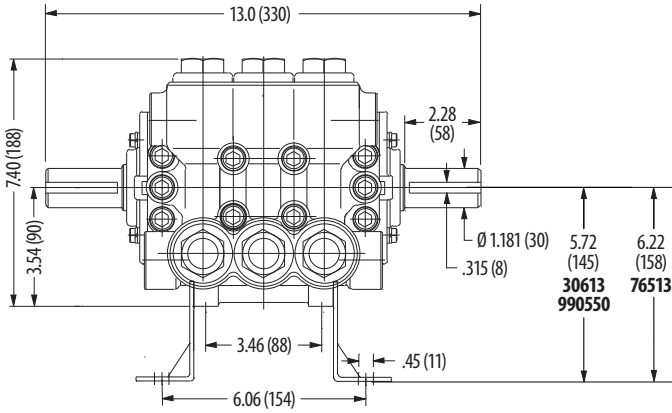

SEAL KITS One (1) seal kit required per pump

PUMP MODELS	NBR (STD)	FPM (.0110)	EPDM (.0220) ◆	FFKM (.0770)
1530, 1530C, 1531	31355	31455*	31753	76682

ITEM (Included in Seal Kits)					DESCRIPTION	QTY
97	17399	14160	46204	701715	O-Ring, Plunger Retainer	3
106	44086	45846	49196	701944	Seal, Low-Pressure with SS-Spring	3
112	14200	11719	48907	701716	O-Ring, Inlet Manifold	3
127	44610	44610	44610	703050	V-Packing	6
155	17629	14183	701491	702705	O-Ring, Spacer	6
156	28243	28243	28243	28243	Backup Ring, Spacer	6

◆ Silicone oil/grease required

* Review material codes for individual items (STG generally maybe used as an alternative)

VALVE KITS Two (2) valve kits required per pump

PUMP MODELS	NBR (STD)	FPM (.0110)	EPDM (.0220) ◆	FFKM (.0770)
1530, 1530C	31360	31460	31773	76360
1531	31271	31281	31773	76360

ITEM (Included in Valve Kits)					DESCRIPTION	QTY
162	48363	48363	48363	48363	Backup Ring, Seat	3
163	26142	14330	701493	702808	O-Ring, Valve Seat	3
164	48596	48596	48688	48688	Seat (Models 1530, 1530C)	3
	48688	48688	48688	48688	Seat (Model 1531)	3
166	670108	670108	670108	670108	Valve	3
167	48687	48687	48687	48687	Spring	3
168	44735	44735	44735	44735	Retainer, Spring	3
170	44794	44794	44794	44794	Washer, Spring Retainer	3
172	17629	14183	701491	702705	O-Ring, Valve Plug	3

◆ Silicone oil/grease required

⚠ CAUTIONS AND WARNINGS

All high-pressure systems require a primary pressure regulating device (e.g. regulator, unloader) and a secondary pressure relief device (e.g. pop-off valve, relief valve). Failure to install such relief devices could result in personal injury or damage to pump or property. Cat Pumps does not assume any liability or responsibility for the operation of a customer's high-pressure system. Read all CAUTIONS and WARNINGS before commencing service or operation of any high-pressure system. The CAUTIONS and WARNINGS are included in each Service Manual and with each Accessory Data sheet. CAUTIONS and WARNINGS can also be viewed online at www.catpumps.com/dynamic-literature/cautions-and-warnings or can be requested directly from Cat Pumps.

WARRANTY

View the Limited Warranty online at www.catpumps.com/literature/cat-pumps-limited-warranty