

DATA SHEET

15 FRAME BLOCK-STYLE PLUNGER PUMP

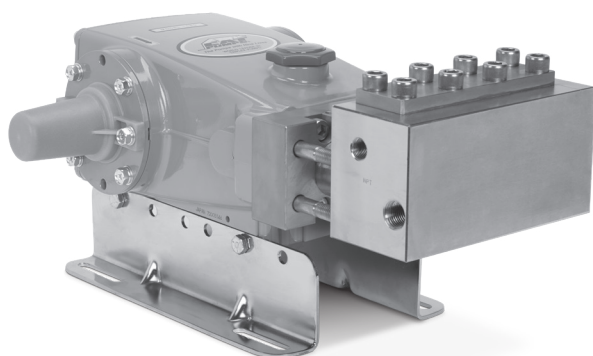

Standard Model: 1570



(Mounting rails sold separately)

FEATURES

- Triplex design offers high-efficiency and low-pulsation.
- Durable V-Packings are lubricated and cooled by pumped liquid.
- Pre-set low-pressure seals deliver secondary protection against external leaks and require no packing adjustment.
- Special high-density, polished, concentric plungers provide a true wear surface and extended seal life.
- 304 Stainless Steel inlet/discharge manifold.
- Pump comes standard with NBR seals. Alternative seal materials are available for higher temperature or chemical compatibility.

SPECIFICATIONS	U.S. Measure	Metric Measure
Flow	6.0 gpm	22.7 lpm
Pressure Range	100–6000 psi	6.9–414 bar
Pump RPM*	1350 rpm	1350 rpm
Inlet Pressure Range	Flooded to 60 psi	Flooded to 4.1 bar
Max. Liquid Temp. (NBR)	160° F	71° C
Alternative seals available for higher temperatures up to 180° F.		
Bore	0.630"	16 mm
Stroke	1.181"	30 mm
Crankcase Capacity	42 oz	1.26 l
Inlet Ports (2)	½" NPT(F)	½" NPT(F)
Discharge Ports (2)	¾" NPT(F)	¾" NPT(F)
Pulley Mounting	Either Side	Either Side
Shaft Diameter	1.181"	30 mm
Weight	68.3 lbs	31 kg
Dimensions	17.99 x 13.37 x 7.01"	457 x 340 x 178 mm

*Pump minimum is 100 RPM

ALTERNATIVE SEAL CONFIGURATION

MATERIAL	SUFFIX CODE	MAXIMUM TEMPERATURE	
NBR	—	160° F	(71° C)
FPM	.0110	180° F	(82° C)

See **Tech Bulletin 002** for inlet conditions and RPM at high temperature.

DETERMINING THE PUMP RPM	Rated gpm	=	Desired gpm
	Rated rpm		Desired rpm
DETERMINING THE REQUIRED HP	hp	=	gpm x psi
	(Electric Brake)		1460
DETERMINING MOTOR PULLEY SIZE	Motor Pulley OD	=	Pump Pulley OD
	Pump rpm		Motor rpm

Refer to pump **Service Manual** for repair procedure and additional technical information.

PARTS LIST

ITEM	PART NUMBER	MATERIAL	DESCRIPTION	QTY
5	126540	STCP R	Screw, HHC, Sems (M8 x 20) (See Tech Bulletin 074, 128)	8
8	134805	ALE	Cover, Bearing (See Tech Bulletin 118, 128)	2
9	855043	FBR	Shim, Split, 2-Piece (See Tech Bulletin 128)	3
10	11340	NBR	O-Ring, Bearing Cover-70D	2
11	43495	NBR	Seal, Oil, Crankshaft	2
12	855044	S	Shim, Split, 2-Piece (See Tech Bulletin 128)	2
15	39060	STL	Bearing, Roller	2
20	126805	BZ	Rod, Connecting Assembly (See Tech Bulletin 074)	3
25	43494	FCM	Crankshaft, Dual-End (30mm)	1
32	43211	ABS	Cap, Oil Filler	1
33	14177	NBR	O-Ring, Filler Cap-70D	1
37	92241	PC	Gauge, Oil, Bubble with Gasket-80D (See Tech Bulletin 074)	1
38	44428	NBR	Gasket, Flat, Oil Gauge-80D	1
40	126541	STCP R	Screw, HHC, Sems (M6 x 20) (See Tech Bulletin 074)	4
48	25625	STCP	Plug, Drain (1/4" x 19 BSP(M))	1
49	23170	NBR	O-Ring, Drain Plug-70D	1
50	133576	ALE	Cover, Rear (See Tech Bulletin 118)	1
51	44834	NBR	O-Ring, Rear Cover-70D	1
53	134927	ALE	Crankcase with Guide Pins (See Tech Bulletin 118, 128)	1
54	27488	S	Pin, Guide	2
64	43507	CM	Pin, Crosshead	3
65	131772	SBZ	Rod, Plunger	3
69	126592	STCP R	Washer, Oil Seal	3
70	43500	NBR	Seal, Oil Crankcase	3
86	131777	D	Collar	3
90	132150	CC	Assembly, Plunger (M16 x 83), with S-Holder	3
100	125649	D	Retainer, Seal	3
101	131740	—	Wick	3
104	126148	NBR	O-Ring, Cylinder-70D	3
105	131783	S	Cylinder, Outer	3
106	48222	NBR	Seal, LPS with S-Spring	3
	76089	ST2	Seal, LPS with SS-Spring	3
110	131778	AL	Block, Housing	1
114	132153	S	Case, Seal	3
115	13986	NBR	O-Ring, Seal Case-70D	3
117	131779	S	Screw, HSH (M10 x 40) (See Tech Bulletin 074)	4
118	165769	S	Plug [1/8" BSP(M)]	3
122	49850	PTFB	Backup Ring, Cylinder	3
123	49382	NBR	O-Ring, Cylinder-90D	3
124	132154	S630	Cylinder, V/P	3
126	131744	PE	Adapter, Female	3
127	43319	SNG	V-Packing	9
128	43318	BB	Adapter, Male	3
159	131788	PTFB	Backup Ring, Inlet Seat	3
160	142807	NBR	O-Ring, Seat, Inlet-90D	3
161	131787	S630	Seat, Inlet	3
162	129638	PTFE	Backup Ring, Discharge Seat	3
163	49104	NBR	O-Ring, Seat, Discharge-90D	3
164	131790	S630	Seat, Discharge	3
165	132679	PVDF	Retainer, Spring, Inlet	3
166	46562	S	Valve	6
167	43750	S	Spring, Valve	6
168	44565	PVDF	Retainer, Spring, Discharge	3
170	131757	S	Washer	3
171	44832	S	Spring, Coil	3
172	49382	NBR	O-Ring, Valve Plug-90D	3
173	49850	PTFB	Backup Ring, Valve Plug	3
174	131791	S	Plug, Valve	3
176	131792	AL	Cover, Valve	1
177	122599	S	Screw, HSH (M12 x 25) (See Tech Bulletin 074)	8
185	132156	S	Manifold, Inlet/Discharge	1
188	131793	S	Screw, HSH (M12 x 90) (See Tech Bulletin 074)	8
250	855046	NY	Protector, Shaft with Two (2) Screws (See Tech Bulletin 128)	1

Italics are optional items. R Components comply with RoHS Directive.

For additional technical information see www.catpumps.com/literature/tech-bulletins.

MATERIAL CODES (Not Part of Part Number): ABS=ABS Plastic AL=Aluminum ALE= Aluminum Epoxy BB=Brass BZ=Bronze CC=Ceramic CM=Chrome-moly D=Acetal

F=Cast Iron FBR=Fiber FCM=Forged Chrome-moly FPM=Fluorocarbon HT=High Temp NBR=Medium Nitrile (Buna-N) NY=Nylon PC= Poly Carbonate

PE=Polyethylene POP=Polypropylene PTFB=Pure Polytetrafluoroethylene w/ Bronze PTFE=Pure Polytetrafluoroethylene PVDF=Polyvinylidene

Fluoride S=304SS SBZ=304SS/Bronze SNG=Special Blend (Buna) ST2=Special PTFE 2 STCP=Steel/Chrome Plated

STL=Steel STZP=Steel/Zinc Plated S630=304SS/Hardened

Standard and optional Seal Kits and Valve Kits listed on pages 3 and 4. Optional Parts and Accessories and Service parts listed on Page 3.

EXPLODED VIEW

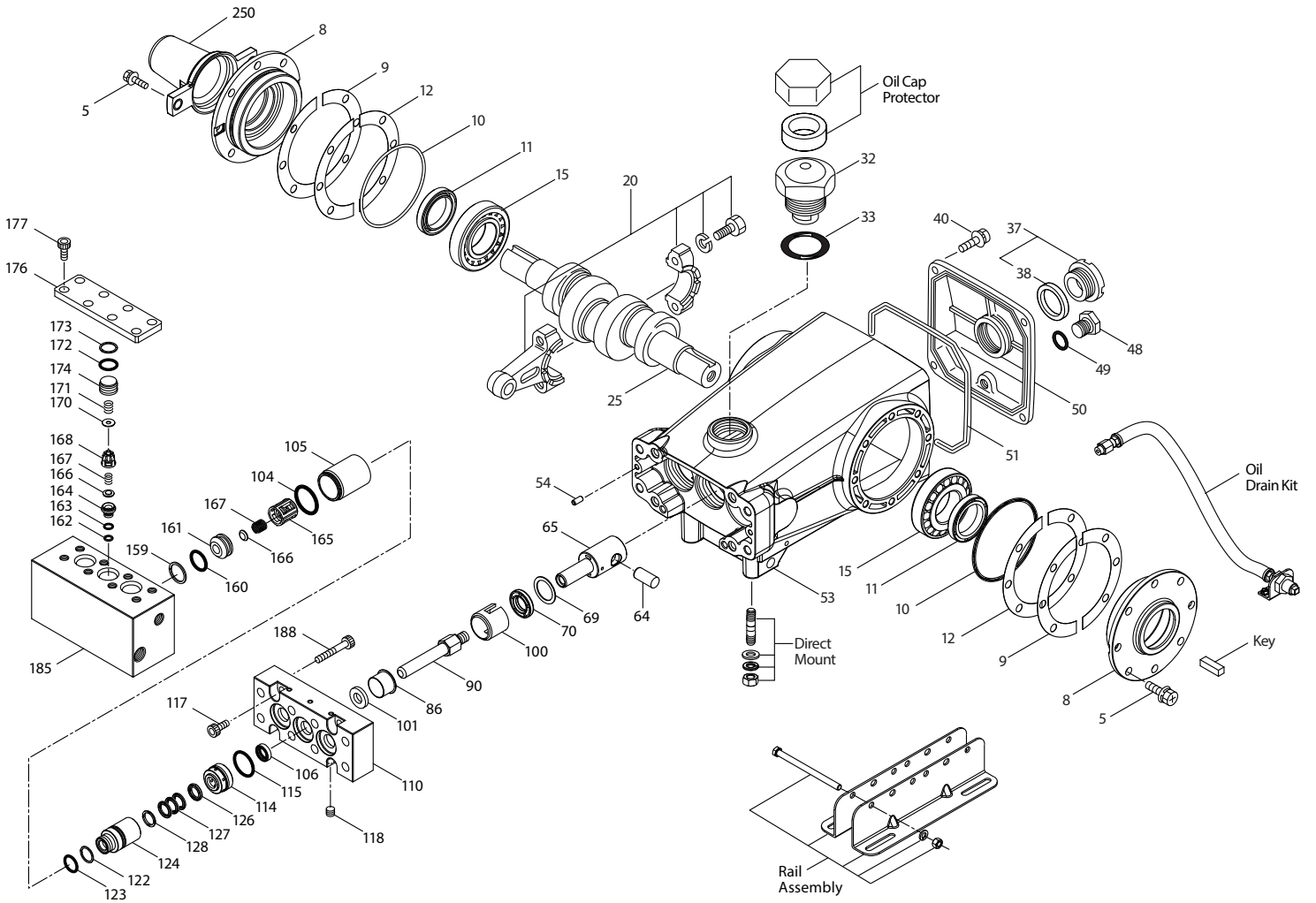

Model 1570
February 2021

OPTIONAL PARTS AND ACCESSORIES

PART	DESCRIPTION	QTY
30067	Key, M8 x 7.5 x 25	1
990036	Key, M8 x 7 x 40	1
30613	Assembly, Rail (5.72" See Dimension Drawing)	1
76513	Assembly, Rail (6.22" See Dimension Drawing)	1
990550	Assembly, Rail (5.72" See Dimension Drawing)	1
30264	Mount, Direct	1
828710	Protector, Oil Cap	1
34334	Kit, Oil Drain	1
30206	Pulley, 10", 2 Groove H	1
30059	Hub, H, 30mm	1
990012	Hub, B, 30mm	1

OPTIONAL PARTS AND ACCESSORIES

PART	DESCRIPTION	QTY
76389	Kit, Seal	1
76390	Kit, Valve	1
6107	Oil, Bottle (21 oz)	2
6124	Gasket, Liquid (3 oz)	1
6119	Lubricant, Anti-seize (2 oz)	1
818577	Head, Complete with NBR Seals and O-Rings	1

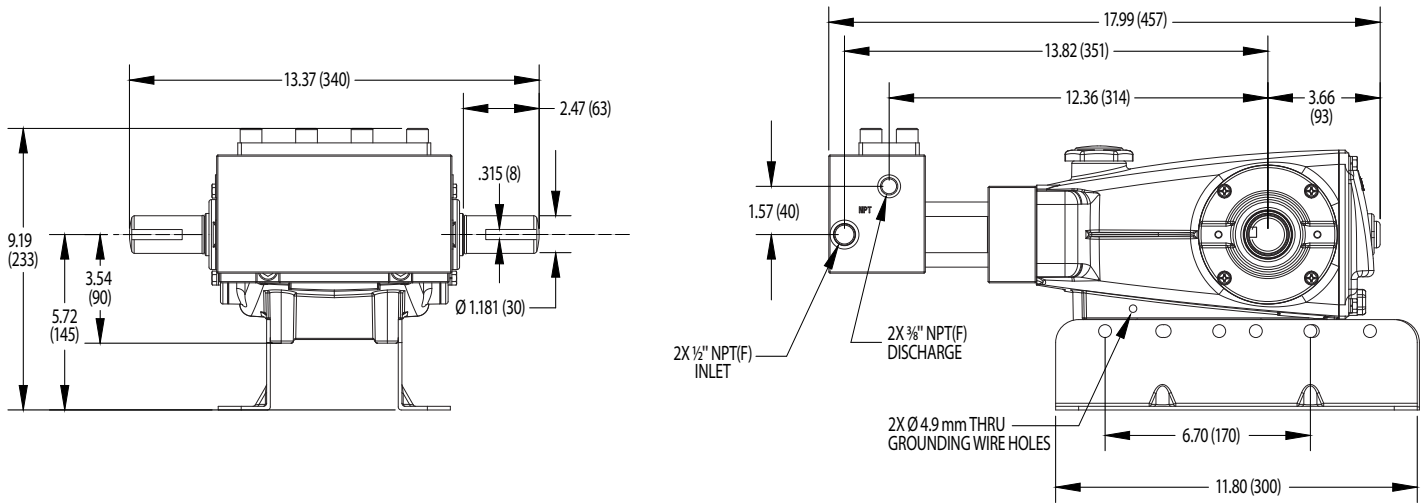

SEAL KITS One (1) seal kit required per pump

PUMP MODELS	NBR (STD)	FPM (.0110)
1570	76389	76670

ITEM (Included in Seal Kits)			DESCRIPTION	QTY
101	131740	131740	Wick	3
104	126148	76663	O-Ring, Outer Cylinder	3
106	48222	670019	Seal, LPS with S-Spring	3
115	13986	76664	O-Ring, Seal Case	3
122	49850	49850	Backup Ring, Cylinder	3
123	49382	49897	O-Ring, Cylinder	3
126	131744	131744	Adapter, Female	3
127	43319	46287	V-Packing	9

VALVE KITS One (1) valve kit required per pump

PUMP MODELS	NBR (STD)	FPM (0.0110)
1570	76390	76679

ITEM (Included in Valve Kits)			DESCRIPTION	QTY
159	131788	131788	Backup Ring, Inlet Seat	3
160	142807	547743	O-Ring, Inlet Seat	3
161	131787	131787	Seat, Inlet	3
162	129638	129638	Backup Ring, Discharge Seat	3
163	49104	76665	O-Ring, Discharge Seat	3
164	131790	131790	Seat, Discharge	3
165	132679	132679	Retainer, Inlet Spring	3
166	46562	46562	Valve	6
167	43750	43750	Spring	6
168	44565	44565	Retainer, Discharge Spring	3
172	49382	49897	O-Ring, Valve Plug	3
173	49850	49850	Backup Ring, Valve Plug	3

⚠ CAUTIONS AND WARNINGS

All high-pressure systems require a primary pressure regulating device (i.e. regulator, unloader) and a secondary pressure relief device (i.e. pop-off valve, relief valve). Failure to install such relief devices could result in personal injury or damage to pump or property. Cat Pumps does not assume any liability or responsibility for the operation of a customer's high-pressure system.

Read all CAUTIONS and WARNINGS before commencing service or operation of any high-pressure system. The CAUTIONS and WARNINGS are included in each Service Manual and with each Accessory Data sheet. CAUTIONS and WARNINGS can also be viewed online at www.catpumps.com/dynamic-literature/cautions-and-warnings or can be requested directly from Cat Pumps.

WARRANTY

View the Limited Warranty on-line at www.catpumps.com/literature/cat-pumps-limited-warranty

CAT PUMPS 1681 94th Lane N.E., Minneapolis, MN 55449-4324 P: (763) 780-5440 F: (763) 780-2958 E: techsupport@catpumps.com www.catpumps.com

©2021 Cat Pumps Inc. All rights reserved. All data contained in this document are based on the latest product information available at the time of publication. Cat Pumps reserves the right to make changes at any time without notice.

PN 993356 Rev H 21030 2/21